



Metering Technology



**DOPAG Adhesive Metering,
Mixing and Dispensing Systems
for the flexible packaging industry**



Hilger u. Kern / Dopag Group

Accurate, reliable

For over 30 years, the Hilger u. Kern / Dopag Group has produced machines and systems for metering, mixing and dispensing adhesives for laminating products such as those found in the flexible packaging industry. A comprehensive choice of continuous output solutions, including piston pump, gear pump and flow meter driven systems, cater for single component, solvent based and solvent free plural component adhesives, which are able to accommodate every type of application in this industry.

Dispensing adhesives in film laminating applications is perhaps rather more critical than it might seem at first glance. With machine speeds running at around 600 metres per minute, any malfunction affecting the metering, mixing or dispensing process that may as a consequence provide uncured adhesive to the film, will have serious repercussions, with potentially disastrous consequences.

DOPAG systems are designed from the outset, to eliminate all possible difficulties of this nature. For example all DOPAG systems intended for use in the flexible packaging industry incorporate independent and permanent monitoring devices as standard, to ensure that plural component adhesive mixing ratios remain within acceptable tolerance limits and flow rates stay constant. In so doing, any likelihood of expensive rejects caused through inaccurate metering is eliminated.

Similarly, potentially harmful overheating of the adhesive is nullified by the use of individual heating circuits that gently and gradually raise the temperature of the adhesive until the precise application temperature is reached, whilst the sealed nature of the systems and in particular the use of pressure feed containers to deliver the adhesive components to the metering systems, allows the systems to be closed down for long periods if required, without the formation of damaging crystallised material caused by air borne moisture.

To satisfy the demanding requirements of the flexible packaging industry, the Hilger u. Kern / Dopag Group has developed metering, mixing and dispensing systems specifically for use in the manufacture of film laminates and appropriate system technology is available for all metering, mixing and dispensing options.

- **eldomix gear pump type metering and mixing system for solvent free two component adhesives**
- **variomix piston pump type metering and mixing system for solvent free two component adhesives**
- **P200 drum pump system for processing single component adhesives**
- **Automatic refilling bung mounted pumps to automatically refill pressure vessels**
- **ladomix V-SB flow meter type metering and mixing system for solvent based two component adhesives**

The Systems



eldomix

gear pump type metering and mixing system for solvent free two component adhesives

DOPAG eldomix systems employ gear pump technology to meet the demand for processing solvent free adhesives. Ease of changing the mixing ratio is a major feature of this type of system and is a simple affair, achieved merely by entering the desired ratio into the controller, making this system ideal for users who may need to change adhesives frequently.

Featuring on-board pressure vessels and individually driven gear pumps, these systems continuously monitor flow rates and mixing ratios by means of integrated volumetric flowmeters. Great care is taken to ensure that air borne moisture does not cause material to crystallise on the gear pump shafts that could lead to failure, by providing in-built, pressurised mesamol lubricating systems.

Both adhesive components are gradually and progressively heated to the optimum pre-set temperature for dispensing by means of separate heating circuits to prevent harmful overheating.

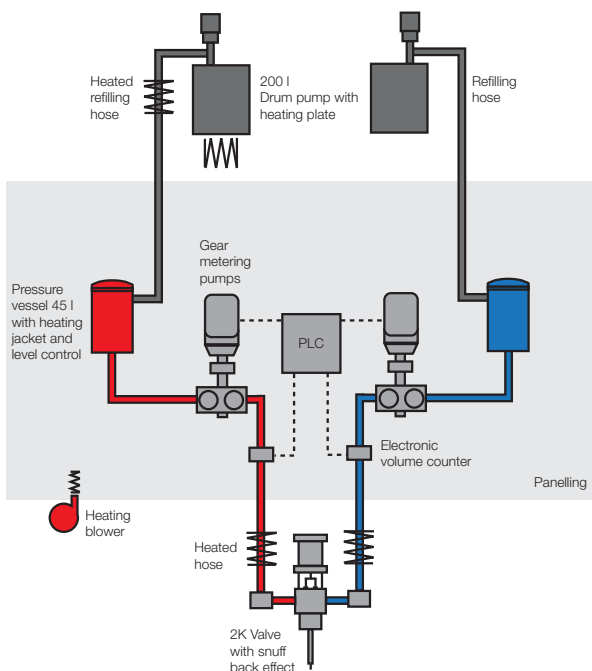



variomix

piston pump type metering and mixing system for solvent free two component adhesives

DOPAG variomix systems feature advanced piston pump technology designed to dispense controlled volumes of adhesive in precise proportions at exactly the right temperature.

During this process, both components of the adhesive are gradually and progressively heated to the optimum temperature for dispensing by means of separate heating circuits in order to prevent harmful overheating.

Both adhesive components are fed from pressure vessels to pneumatically driven double acting piston type metering pumps, where they are proportioned before being fed to the mixer via volumetric flowmeters that constantly monitor the flow rate and mixing ratio of the two components.

Both components remain completely separate until they enter a disposable mixer, thus minimising waste and avoiding the need for flushing solvents.

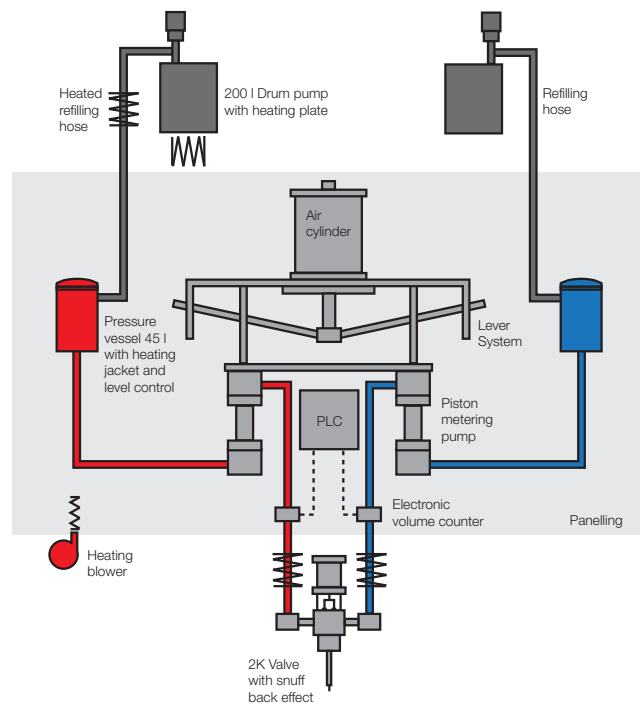



P200 drum pump

system for processing solvent free single component adhesives

The DOPAG P200 drum pump system delivers adhesive to the laminating machine directly from 200 litre size drums. The pneumatically driven reciprocating piston pump is mounted onto twin post pneumatic rams, which along with its follower plate assist in priming the pump with adhesive, whilst simultaneously wiping the sides of the drum clean, minimising wastage.

Progressive heating zones from the pump to the dispensing valve, via an in-line heater and heated hose assembly, steadily increase the temperature of the adhesive until it reaches its optimum at the point of application.

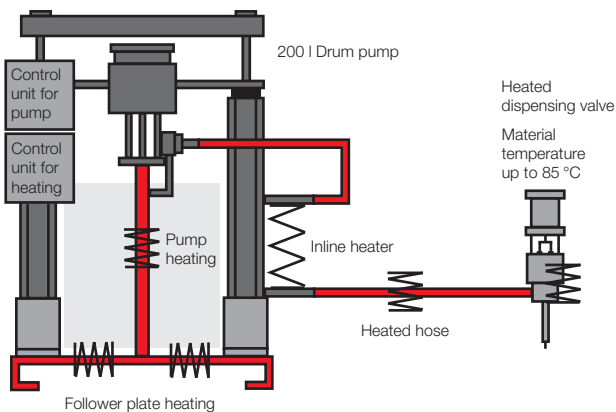

Automatic refilling

bung mounted pumps to automatically refill pressure vessels

Optionally, DOPAG bung mounted pumps can be used to automatically refill pressure vessels on any of the DOPAG plural component systems, allowing production to continue uninterrupted, without the need for downtime caused by manually refilling the pressure vessels.

Mounted onto pneumatically powered lift mechanisms, the pumps fit snugly and easily into the bung holes of standard 200 litre drums, preventing the possibility of air entering the system.



ladomix

flow meter type metering and mixing system for solvent based two component adhesives

The DOPAG ladomix V-SB system has been specifically developed to supply solvent based two component adhesive to flexible laminating systems that require exceptionally fine and accurate control of the mixing ratio.

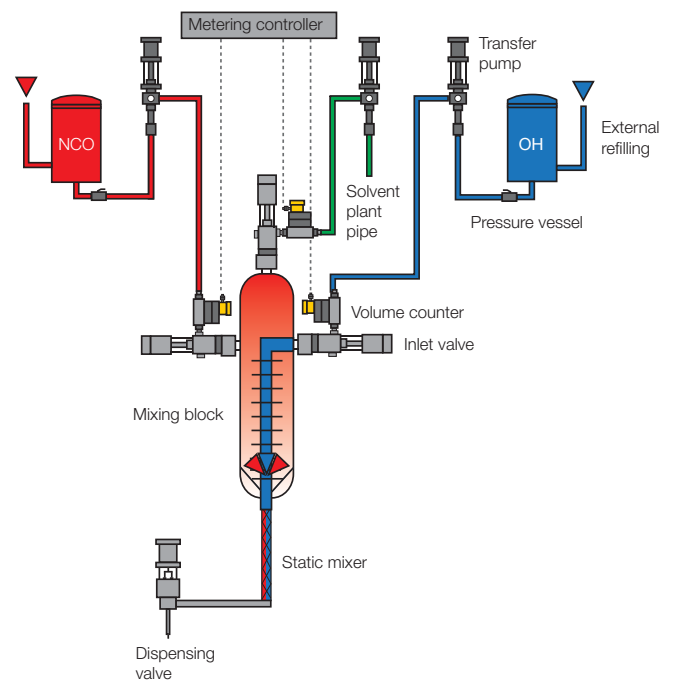

This ability to closely control the mixing ratio during processing is due to the use of VOLU-MIX technology, which uses electronically controlled volumetric flowmeters that allow integrated monitoring and automatic regulation of the chosen mix ratio, resulting in particularly precise metering accuracy.

All electrical and electronic components in this system are explosion protected and conform to the ATEX directive.

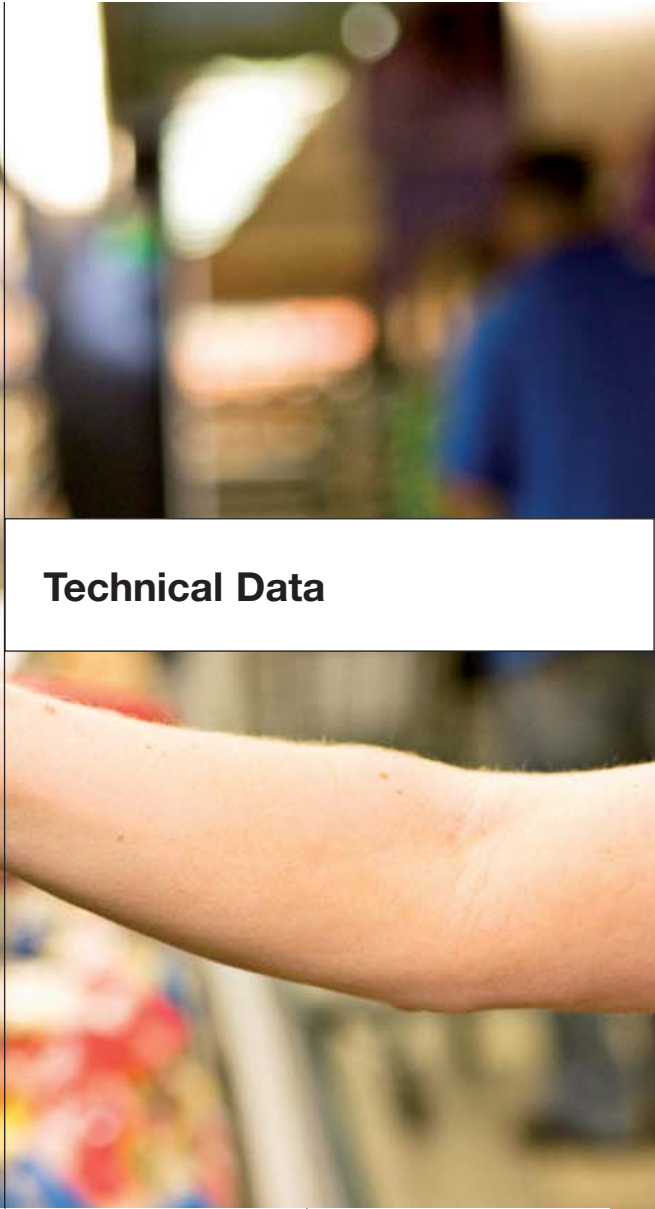



Technical Data

				
	eldomix L3/L4	variomix L1 to L14	P200 drum pump	ladomix V-SB
Max. output rate	2.5 l/min	2 to 4 l/min	0.6–3 l/min	7 l/min
Mixing ratio	100:100 to 100:10	100:100 to 100:10	N/A	100:2:30-200 to 10:100:30-200 (NCO:OH:Solvent)
Max. working pressure	70 bar	200 bar	250 bar	100 bar
Material characteristics	Two component, solvent free	Two component, solvent free	Single component, solvent free	Two component, solvent based
Viscosity range	50 to 80,000 mPa s	50 to 80,000 mPa s	Up to 2,500,000 mPa s	Most popular solvent based adhesives
Material supply	Pressure vessels 45 l	Pressure vessels 45 l	200 l drum pump	Pressure vessels 45 l
Mixing system	Static mixing system - 2K valve (snuff back effect) - Disposable static mixer	Static mixing system - 2K valve (snuff back effect) - Disposable static mixer	N/A	Pre-mix chamber and static mixer
Weight	340 to 650 kg	285 to 620 kg	approx. 300 kg	approx. 500 kg

Hilger u. Kern / Dopag Group

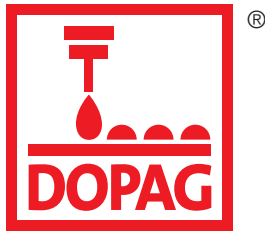

Germany

Hilger u. Kern GmbH
Industrietechnik
Käfertaler Straße 253
68167 Mannheim

☎ +49 621 3705-0
✉ +49 621 3705-200
info@hilger-kern.de
www.hilger-kern.com

Vertriebsbüro Mitte 1
68167 Mannheim
☎ +49 171 8087282
VBMitte@hilger-kern.de

Vertriebsbüro Mitte 2
68167 Mannheim
☎ +49 171 8087299
VBMitte@hilger-kern.de

Vertriebsbüro Nord
30880 Laatzen
☎ +49 171 8087290
VBNord@hilger-kern.de

Vertriebsbüro Ost
99831 Creuzburg
☎ +49 171 8087303
VBOst@hilger-kern.de

Vertriebsbüro Süd
86391 Stadtbergen
☎ +49 171 8087285
VBSued@hilger-kern.de

Vertriebsbüro West
46238 Bottrop
☎ +49 171 8241397
VBWest@hilger-kern.de

China

Hilger u. Kern
Rep. Office Shanghai
☎ +86 21 3368 7775
office@hilger-kern.cn

Switzerland

DOPAG Dosiertechnik
und Pneumatik AG
Langackerstrasse 25
6330 Cham

☎ +41 41 7855-757
✉ +41 41 7855-700
info@dopag.ch
www.dopag.com

Denmark

DOPAG SCAN ApS
Roskilde
☎ +45 45 828090
info@dopag.dk

United Kingdom

DOPAG (UK) Ltd.
Droitwich
☎ +44 1299 250740
uksales@dopag.com

France

DOPAG Sarl
Valence
☎ +33 4 75419060
contact@dopag.fr

Italy

DOPAG ITALIA S.r.l.
Turin
☎ +39 011 9348888
info.it@dopag.com

Malaysia

DOPAG FAR EAST
SDN BHD
Selangor
☎ +60 3 78064564
info@dopag.com.my

USA

DOPAG (US) Ltd.
Cincinnati
☎ +1 513 682 7865
ussales@dopag.com

The Hilger u. Kern / Dopag Group, with more than 300 employees,

8 subsidiaries and 24 distributors, is one of the leading manufacturers

of metering and mixing systems in the world for plural component

polymers and single component media such as greases, oils and pastes.

For more than 30 years the group has developed systems and

components to suit your individual needs.